

MG OPERATOR

DESIGNED FOR STANDARD DUTY USE

INDUSTRIAL GEAR HEAD OPERATORS

Standard Features and Benefits

- Gear-Head construction at the price of a belt-drive operator
- Compact operator/mounting configuration is ideal for coiling doors - operators always fit within the coil height dimension
- Consistent mounting, appearance and wiring - across full line of operator models
- Considerably lighter weight than competitive belt-drive and gear-head operator models
- Auxiliary chain for emergency operation, just pull to operate
- UL Listed
- Cycle counter
- Terminal connection for a monitored entrapment protection device
- 24 VDC warning output signal when the door is moving
- Onboard Open/Close/Stop buttons
- Close override if the entrapment protection device short circuits

Option:

- Module for secondary monitored entrapment protection device
- Programmable timer to close

Standard Components

Drive Reduction: Lubricated, heavy-duty gears.

Auto-Reset Thermal Protection: Prevents motor burnout.

Limit Switches: Linear driven, fully adjustable screw-type cams.

Operator Safety Feature: Activating “Open,” “Stop” or a remote transmitter button stops the movement of a closing door.

Pre-Wired for Sensing Edge/Sensing Devices: A sensing edge, photo eyes or other detection devices can be easily connected. Standard one second time delay prior to reversing prevents damage to door and operator.

Standard Exterior Radio-Control Terminal: Provides for easy and fast connection of radio controls.

Brake: Maintenance free, solenoid actuated brake. No adjustment required for the life of the operator.

Bearings: Heavy-duty bearings are used at all rotation points.

Auxiliary Chain Hoist: Automatically engages and disengages as hand chain is operated. Cut-off switch prevents motor operation when the chain is in use.



Models

Model	MGR 33/MGH 33	MGR 50/MGH 50	MGR 75/MGH 75
Horsepower	1/3 HP	1/2 HP	3/4 HP
Voltage	115V/230V 460V 575V	115V/230V 460V 575V	115V/230V 460V 575V
Phase	1 & 3	1 & 3	1 & 3
Frequency	50 Hz** / 60 Hz	50 Hz** / 60 Hz	50 Hz** / 60Hz
Duty	20 cycles/hr*	20 cycles/hr*	20 cycles/hr*
Drive Chain	#50	#50	#50
Internal Lock Sensor	Optional (MGRL 33) / Optional (MGHL 33)	Optional (MGRL 50) / Optional (MGHL 50)	Not Available
Auxiliary Hand Chain	Not Provided (MGRL 33) / Included (MGHL 33)	Not Provided (MGRL 50) / Included (MGHL 50)	Not Provided (MGR 75) / Not Provided (MGH 75)

Above products are protected by patent #6,900,602 #11,446,561 and #7,055,283. Other patents pending.

*Medium-Duty Operator - tested to perform for up to 20 cycles in one hour, not to be used for consecutive hours. If consecutive hours or continuous duty is required, refer to the SG Super-Duty Operator.

**Additional lead time may apply. Please contact factory for details.

Mounting Options

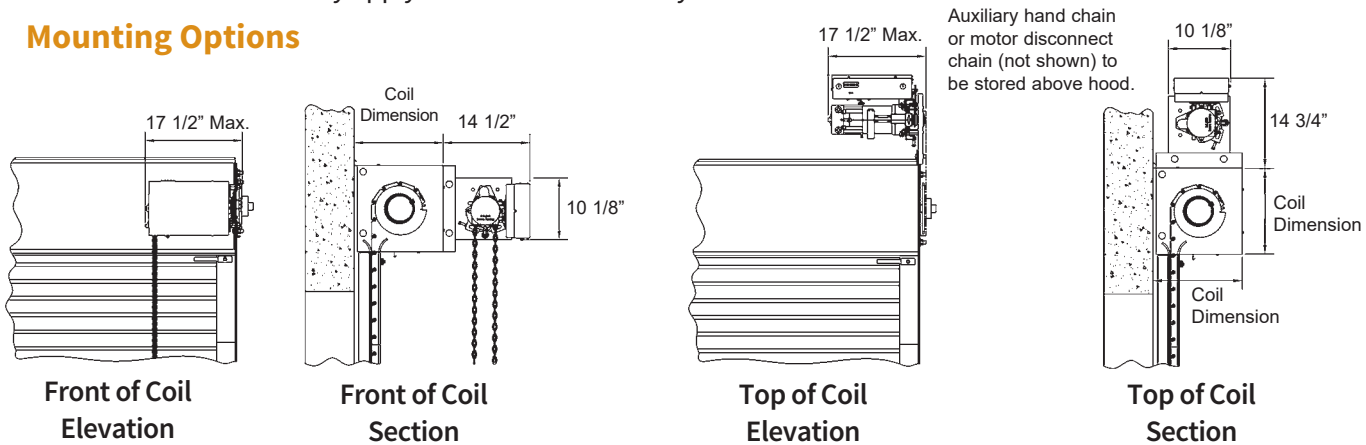

Details and Clearances

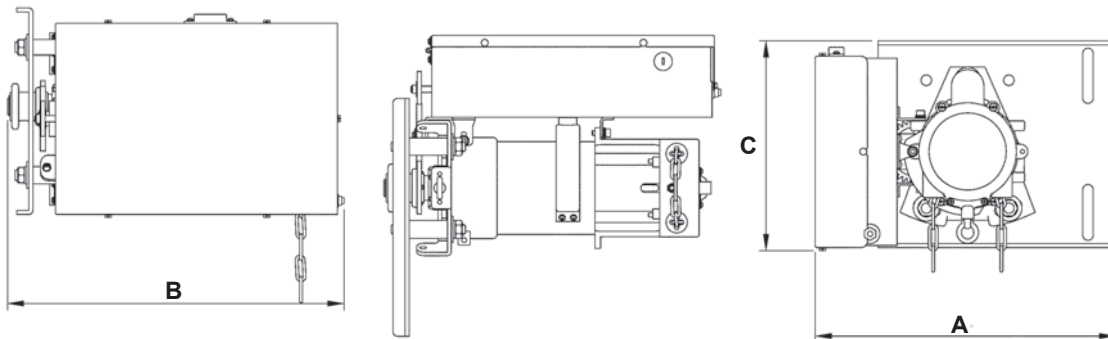

MG Series			
	A	B	C
1/3 HP	14 1/2"	16 7/8"	10 1/8"
1/2 HP	14 1/2"	17 1/8"	10 1/8"
3/4 HP	14 1/2"	17 3/8"	10 1/8"